

# **Installation, Operation & Maintenance Manual**

## **Style 240/242**

---



Date:



*The Expansion Joint  
and  
Check Valve People*

2431 North Wigwam Dr.  
Stockton, CA 95205  
Phone: 800-344-3246  
Fax: 209-943-0242  
Email: [sales@procoproducts.com](mailto:sales@procoproducts.com)



## Table of Contents

1.0 Introduction:	2
2.0 Storage and Handling:	2
2.1 Storage:	2
2.2 Large Joint Handling:	3
3.0 Prior to Installation:	3
3.1 Verify System Parameters:	3
3.2 Pipe Anchoring/Supports:	3
3.3 Pipe Alignment:	4
3.4 Concurrent Movement Calculation:	5
3.5 Unpack/Inspect Expansion Joint:	5
4.0 Expansion Joint Installation:	6
4.1 Installation Precautions:	6
4.2 Control Unit Installation Configurations:	7
4.3 Installation Procedures:	9
5.0 System Testing:	14
6.0 Operation and Maintenance Procedures:	14
7.0 Trouble Shooting:	15
Appendix A: Torque Data:	16
Appendix B: Installation Record Sheet:	18

## 1.0 Introduction:

Proco Products, Inc. (Proco) rubber expansion joints are flexible connectors fabricated of natural or synthetic elastomers and fabrics and if necessary metallic reinforcements, to provide stress relief in piping systems due to thermal expansion/contraction, mechanical vibration and/or system movements. This installation, operation and maintenance manual will cover the general practices for the proper installation, operation and maintenance of the Proco molded spherical type rubber expansion joints. The Proco style of rubber expansion joints covered in this guide include the style 240 and style 242, molded rubber expansion joints incorporating floating flanges.

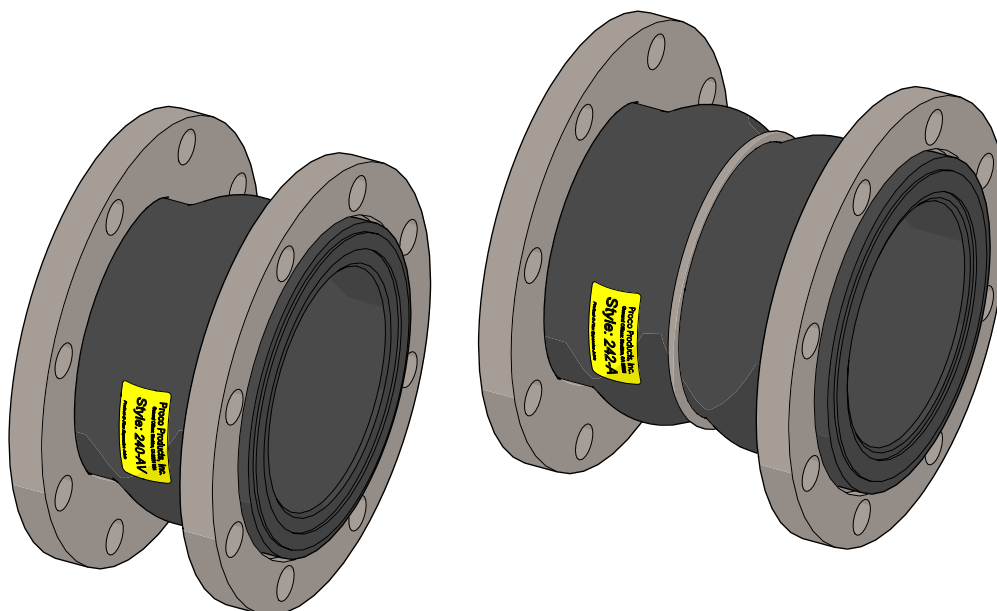

**Figure 1: Style 240 & 242**

Note: The style 242 comes with a reinforcing ring in-between the 2 arches and depending on the size the reinforcing ring is either embedded in the carcass or exposed.

## 2.0 Storage and Handling

### 2.1 Storage

#### 2.1.1 Inside:

The ideal storage location for an expansion joint is in a warehouse setting with a relatively dry and cool location. Store the expansion joint face down on a pallet or wooden platform. Do not lay other boxes on top of the expansion joint or expansion joint box.

#### 2.1.2 Outside

If the expansion joint is to be stored outside, keep the expansion joint protected in a waterproof protected crate until ready for installation. Also keep the expansion joint protected from any external elements such as direct UV exposure and/or animals. Do not lay other boxes on top of the expansion joint or expansion joint box.

## 2.2 Large Expansion Joint Handling:

In the case of large size expansion joints, special care should be taken in loading, hoisting and lowering, being careful not to hit against adjacent equipment, forklift tines, crane cables, etc. Lift utilizing nylon slings around the exterior of the expansion joint as shown in Figure 2. Position the slings to each side of the arch; this will help prevent any damage to the arch as well as to ensure that the weight is evenly distributed during installation.

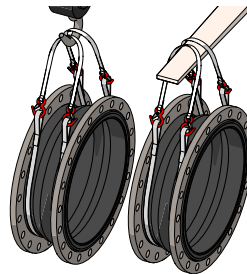

**Figure 2: Large Joint Handling**

## 3.0 Prior to Installation:

### 3.1 Verify System Parameters

Check the system design parameters for the point of installation to ensure that the supplied expansion joint meets the system requirements and that the system requirements do not exceed the rated capabilities of the supplied expansion joint. (Pressure, Temperature, Material Compatibility, System Movements)

### 3.2 Pipe Anchoring/Supports

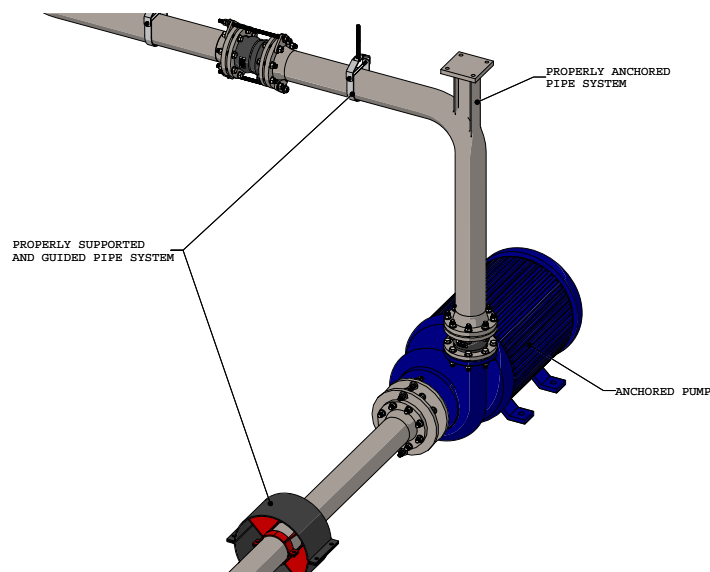

**Figure 3: Properly Anchored and Supported/Supported/Anchored System**

#### 3.2.1 Anchoring:

Solid anchoring is required wherever the pipeline changes direction and expansion joints should be located as close as possible to anchor points. If proper anchor points are not used, the pressure thrust may cause excessive movements in the expansion joint and cause damage.

### 3.2.2 Supports:

Check the piping supports where the rubber expansion joint will be installed. Piping to and from the location of installation for the expansion joint must be properly supported and guided to ensure that the weight of the piping is not transferred to the expansion joint.

### 3.3 Pipe Alignment

Inspect the system for proper alignment as stated in the procedures listed below for axial, lateral, angular and torsional alignment. Piping misalignment in the system should not exceed a maximum of  $\pm 1/8"$  per the Fluid Sealing Association (FSA). If the maximum allowable misalignment is exceeded, the piping should be corrected before installation of the expansion joint. The piping must be prepared to receive the rubber expansion joint, never the contrary, as this would result in compressing, extending, laterally deflecting or angularly bending the expansion joint until it fits into the available clearance for installation. This will result in additional movements for the expansion joint, thereby decreasing its movement capabilities during operation and lead to a possible failure.

#### 3.3.1 Axial Misalignment

To measure for axial misalignment, measure the perpendicular distance from the inside of one mating flange to the inside of the other, the area in which the expansion joint is to be installed. This measured dimension should correspond to the ordered expansion joint's face-to-face or overall length dimension otherwise an axial misalignment is indicated.

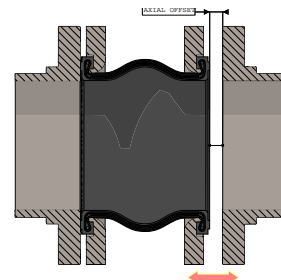

Figure 4: Axial Misalignment

#### 3.3.2 Lateral Misalignment

To measure for lateral misalignment, place a level on the outside edge of the mating flanges and measure the distance across. Repeat the measurement at least 3 times to obtain a total of 4 measurements evenly distributed around the circumference of the mating flanges (6-8 total measurements for large ID expansion joints). Any variation in the measured dimensions and an inconsistency in the level, indicates a lateral misalignment.

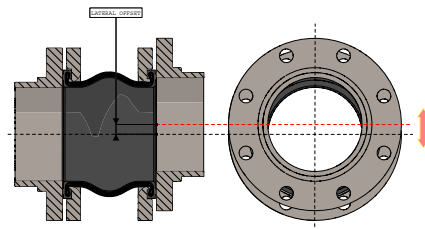

Figure 5: Lateral Misalignment

#### 3.3.3 Angular Misalignment

To measure for angular misalignment between mating flanges, the distance from one mating flange to the other will need to be measured. Measure the perpendicular distance from the inside of one mating flange to the inside surface of the other mating flange. Take several of these measurements in various positions around the mating flanges. Any variation in the measured dimensions indicates that the mating flanges are not parallel and are angularly misaligned.

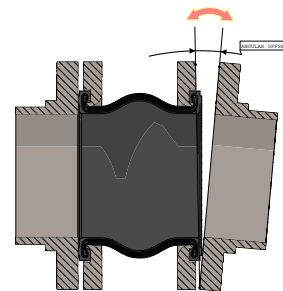
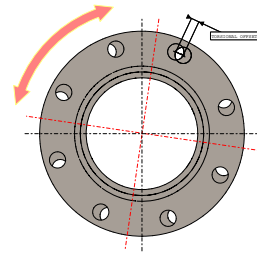

Figure 6: Angular Misalignment

### 3.3.4 Torsional Misalignment

For installations utilizing control units with the Style 240 or 242 molded spherical type expansion joints, check the flange bolt pattern on each mating flange and ensure the bolt holes on each flange line up to each other. Any variation as shown in Figure 7 will indicate a torsional misalignment and may interfere with the proper installation of the control units.



**Figure 7: Torsional Misalignment**

### 3.4 Concurrent Movement Calculation

Concurrent movements are developed when two or more movements in a pipe system occur at the same time. To perform the calculation for concurrent movements when a pipe system has more than one movement, use the following equation:

**Equation 1: Concurrent Movement Calculation:**

$$\frac{\text{Actual Axial}}{\text{Rated Axial}} + \frac{\text{Actual Lateral}}{\text{Rated Lateral}} + \frac{\text{Actual Angular}}{\text{Rated Angular}} < 1$$

The calculation must be <1 for the expansion joint to operation within the concurrent movement capabilities.

Note: Lateral offsets can be found in two planes.

### 3.5 Unpack/Inspect Expansion Joint:

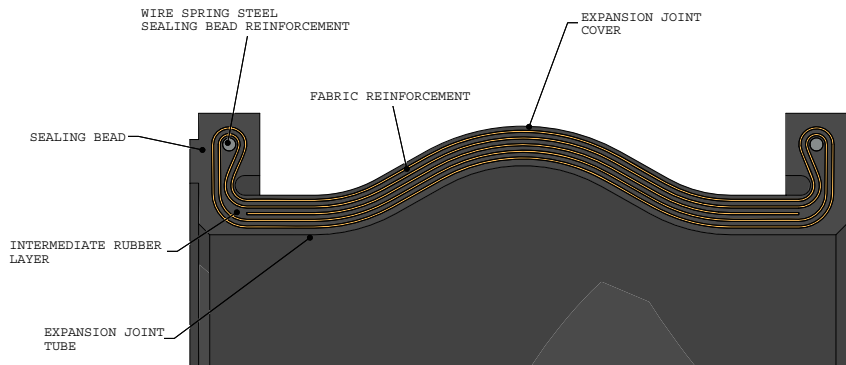

**Figure 8: Rubber Expansion Joint General Materials of Constructions**

Remove the expansion joint from the packaging and if applicable verify that the tag information corresponds with the point of installation into the system. Check the outer cover and the internal tube or bonded liner depending on the style of expansion joint ordered for any damage before placing in service. The cover and tube/liner are designed to keep harmful materials from penetrating the carcass of the joint. Penetration of the cover or tube/liner by harmful materials can cause premature failure of the expansion joint. If the outer cover and/or inner tube/liner is damaged during unpacking or installation contact Proco Products, Inc. by phone: 209-943-6088, by facsimile: 209-943-0242 or by e-mail: sales@procoproducts.com, to determine a course of action before the expansion joint is placed into service.

## 4.0 Expansion Joint Installation:

### 4.1 Installation Precautions:

#### 4.1.1 Adjacent Equipment:

Never install rubber expansion joints next to wafer-type check or butterfly valves. Serious damage can result to a rubber expansion joint of this type unless installed against full-faced flanges.

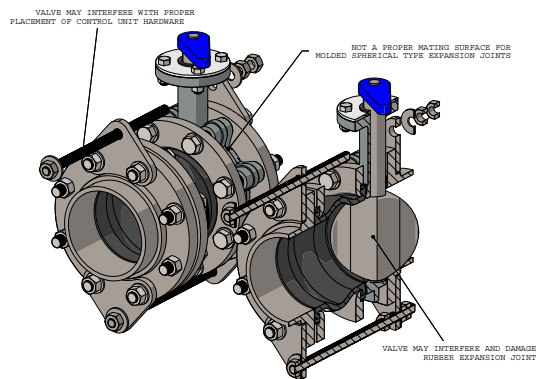

**Figure 9: Adjacent Equipment Precaution**

#### 4.1.2 Insulating Over Expansion Joint:

It is suggested not to insulate over a non-metallic expansion joint. If insulation is required, it should be made removable to permit easy access to flanges. Removable insulation will facilitate periodic inspection of the expansion joint material and allow for tightening of expansion joint bolts.

Note: Insulation could cause restriction of expansion joint movement and/or excessive heating of the expansion joint material to exceed the maximum rated capability of the expansion joint.

#### 4.1.3 Heat Tracing Over Expansion Joint:

Do not use heat tracing over expansion joints.

#### 4.1.4 Welding Near Expansion Joints:

Take precautions when welding next to or near a rubber expansion joint. Weld splatted can damage the rubber material, decreasing overall performance during operation. If welding near a rubber expansion joint it is suggested to use a welding blanked to protect against any damage.

#### 4.1.5 Painting over Expansion Joints:

Do not paint over the rubber element of the expansion joint.

#### 4.1.6 Multiple expansion joints in line:

Never install more than one standard expansion joint assembly between two main anchors unless otherwise specified.

4.2 Control Unit Installation Configurations:

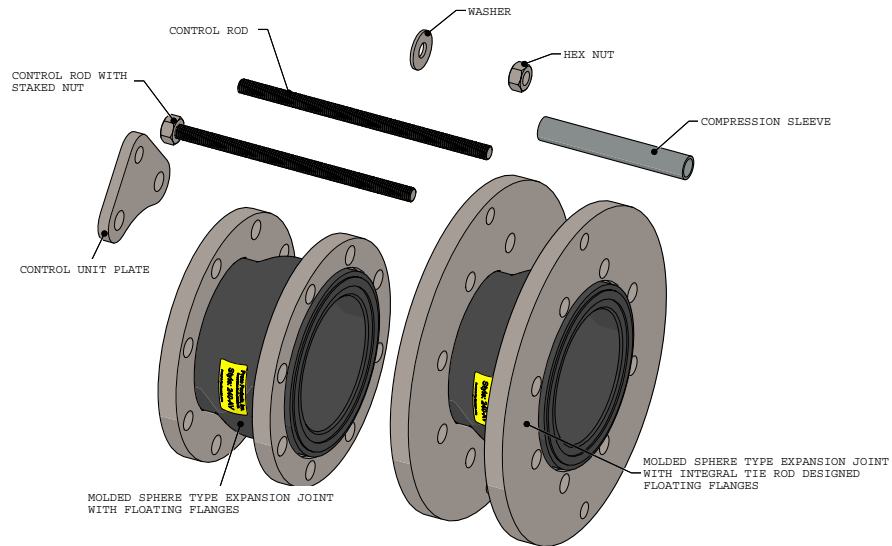
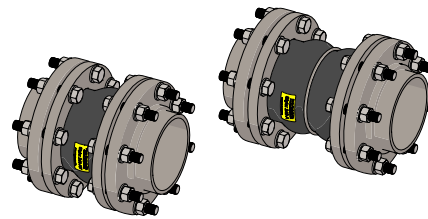

**Figure 10: General Installation Components**

Note: Integral Tie Rod designed floating flanges come in multiple styles and the one depicted is of a general style.

4.2.1 No Control Units Configuration:

The installation configuration shown in Figure 11 does not utilize control units. This configuration is only applicable for properly anchored and supported pipe systems.



**Figure 11: No Control Unit Configuration**

4.2.2 Figure 1: Limit Rod Configuration:

The Figure 1: Limit Rod configuration shown in Figure 12, otherwise known as Figure 1 is designed to control only the extension capabilities of the expansion joint as well as restrain the pressure thrust loads for non-properly anchored systems.

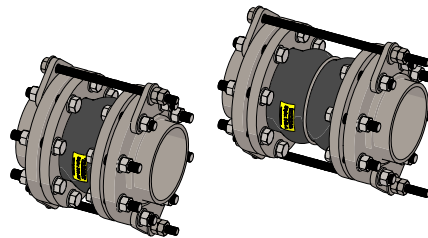

**Figure 12: Figure 1 Limit Rod Configuration**



4.2.3 Figure 2: Control Rod Configuration:

The Figure 2: Control Rod configuration shown in Figure 13, otherwise known as Figure 2 is designed to control both the extension and compression capabilities of the expansion joint as well as restrain the pressure thrust loads experienced across the expansion joint.

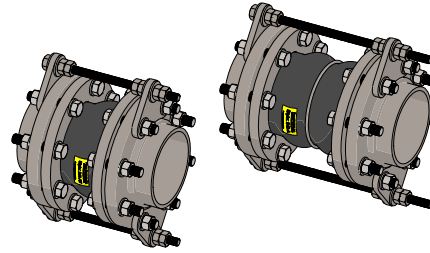

Figure 13: Figure 2 Control Rod Configuration

4.2.4 Figure 3: Compression Sleeve Configuration:

The Figure 3: Compression Sleeve configuration shown in Figure 14, otherwise known as Figure 3 controls both the extension and compression capabilities of the expansion joint as well as restrain the pressure thrust loads experienced across the expansion joint. Instead of utilizing internal hardware to control the compression capabilities a compression sleeve is used.

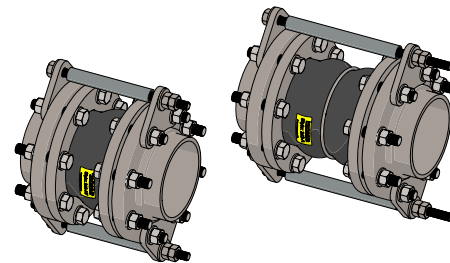

Figure 14: Figure 3 Compression Sleeve Configuration

4.2.5 Integral Tie Rod (ITR) Configuration:

The integral Tie Rod (ITR) designed configuration integrates the control unit plates into the floating flanges when there is a space limitation, flange material conflict or other circumstances where this design is appropriate for the system. The ITR designed floating flanges come in multiple configurations/styles depending on number of control rods specified with either internal hardware or compression sleeves. The ITR design is also designed to restrain the pressure thrust loads experienced across the expansion joint.

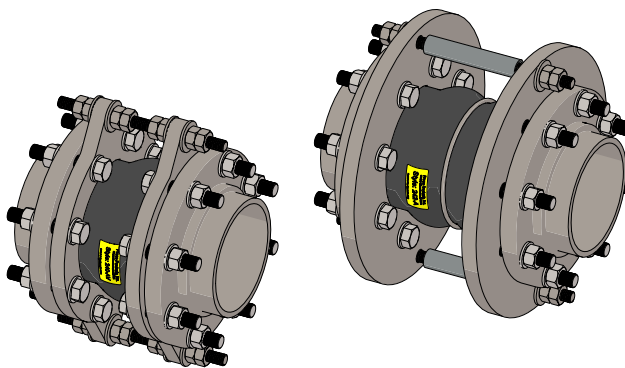

Figure 15: ITR Configuration

Note: Integral Tie Rod designed floating flanges come in multiple styles and the ones shown are of a general style.

#### 4.3 Installation Procedures:

##### 4.3.1 Step 1: Inspect

Inspect the mating flanges to ensure that they are undamaged and clean and free of all foreign matter before installing the rubber expansion joint. A flat faced mating flange is preferred. If raised face flanges are used, the use of a ring gasket is required to prevent the metal flange faces from cutting the rubber bead during installation. If the mating flanges are plastic or FRP and control units are utilized then it is recommended to use a stiffener ring to reinforce the mating flange unless otherwise specified.

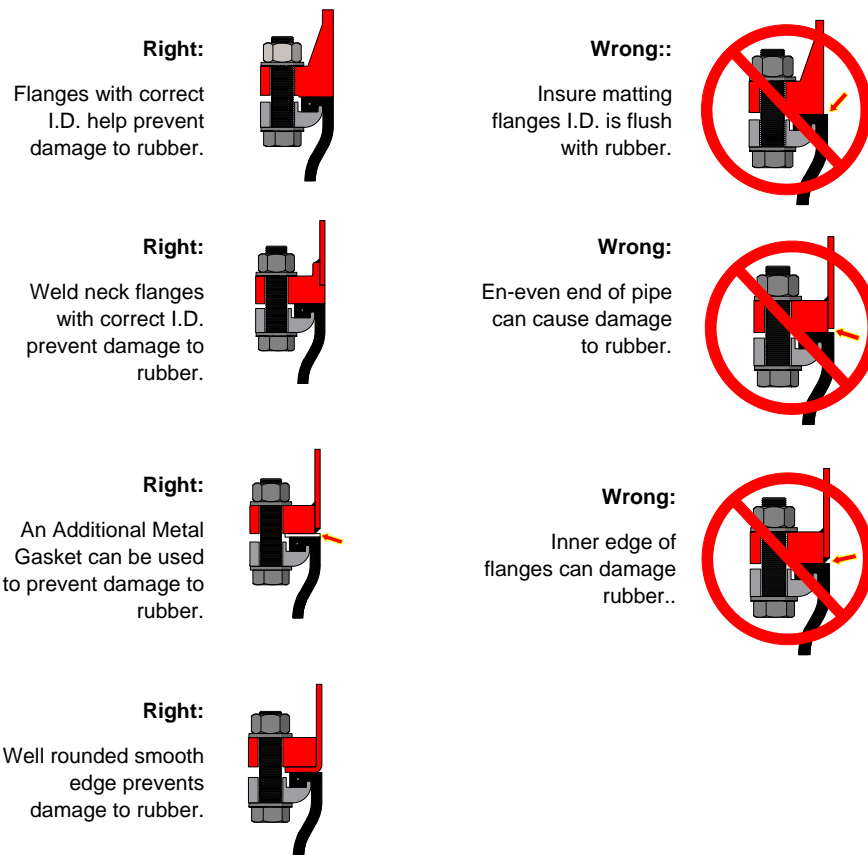

**Figure 16: Flange Preparation**

##### 4.3.2 Step 2: Align into System

Place and align the expansion joint into the system. Take care when installing the expansion joint into the system to prevent and damage to the expansion joint, refer to section 2.2 for large joint handling if applicable.

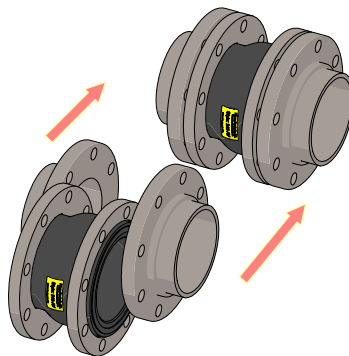
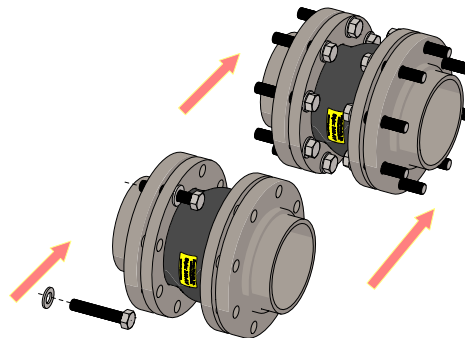

**Figure 17: Align into System**

Note: It is acceptable, but not necessary to lubricate the expansion joint mating surface with a thin film of graphite in Glycerin or water to ease disassembly at a later time. (Petroleum lubricants should not be used on rubber expansion joints.)

**4.3.3 Step 3: Add Flange Bolting**

Secure the floating flanges in place with the flange bolting (supplied by other) so that the bolt head and washer are against the floating flanges as shown in Figure 18, leaving the finishing nuts and washers off to allow for the installation of additional hardware. The use of stud bolting is acceptable as long as no more than 2-4 threads extend past the nut facing the expansion joint. Excessive amounts of threading extending toward the expansion joint can cause damage to the expansion joint as it expands resulting in a reduced service life and an increased possibility of failure.



**Figure 18: Add Flange Bolting**

**4.3.4 Step 4: Attach Control Unit Plates (If Applicable)**

For assemblies utilizing control unit plates, attach the control unit plates to the outside edge of the mating flange as shown in Figure 19 otherwise proceed to step 5. The control unit plates should be evenly spaced around the circumference of the mating flange to help evenly distribute the pressure thrust loads experienced across the expansion joint. Note that the number of control units used is directly correlated with the operating pressure of the system.

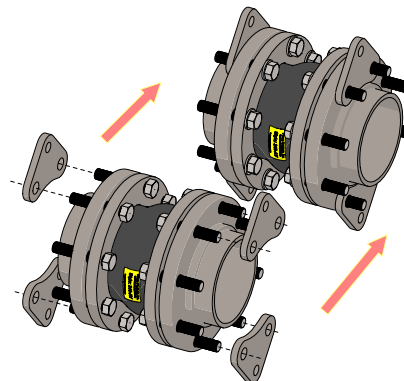

**Figure 19: Add Control Unit Plates**

#### 4.3.5 Step 5: Tighten Flange Bolting

Once the expansion joint and appropriate hardware are in place complete the installation of the flange bolting and tighten all bolts and nuts to a “snug” tight fit before torquing. Torquing should then be accomplished in steps gradually and as evenly as possible around the flange. The bolts should be tightened in an alternating sequence similar to a star pattern shown in Figure 21 to within the proper torque range specified for the size and style of expansion joint to be installed. Refer to appendix A for the proper ranges of torque values as well as further examples of the proper patterns used for torquing the flange bolting.

Note: Never tighten flange bolting on the rubber expansion joint to the point where there is metal to metal contact between the mating flange and floating flange. This type of tightening will crush the rubber sealing bead and cause a premature failure.

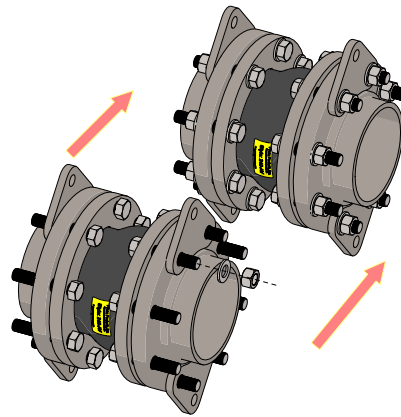

Figure 20: Complete Installation of Flange Bolting

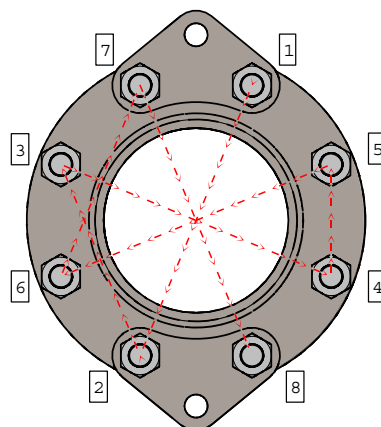
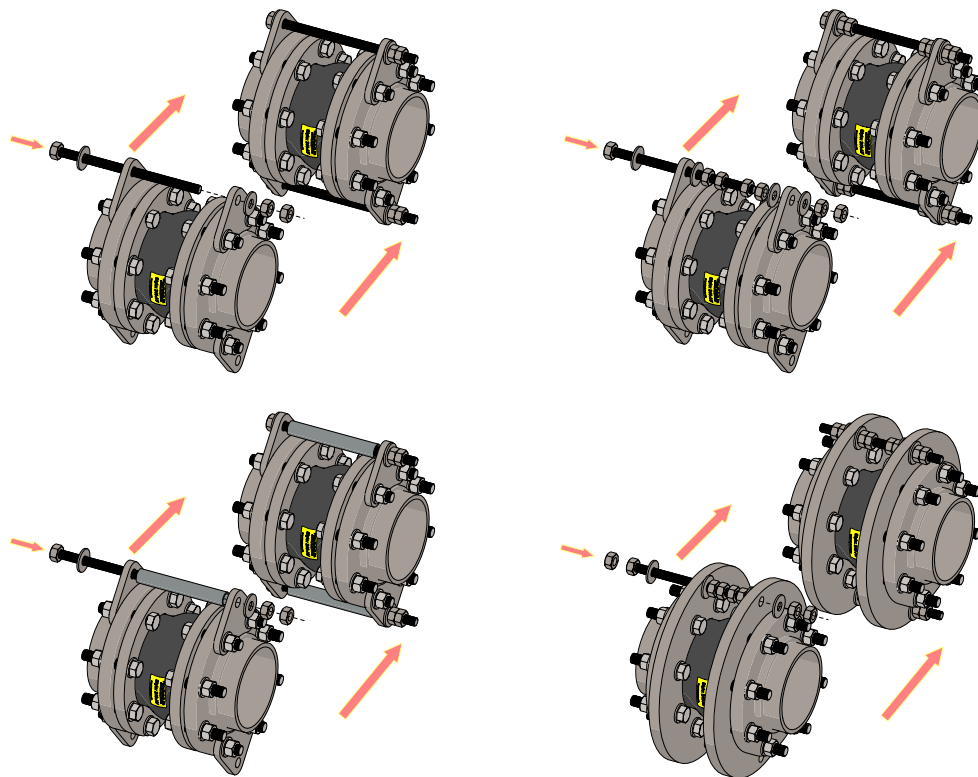

Figure 21: Flange Bolting Sample Torque Pattern

4.3.6 Step 6: Insert Control rod and Appropriate Hardware

Insert the control rod or staked control rod through the control unit plates/ITR Floating flanges control rod holes while adding the appropriate hardware for the type of control unit configuration to be installed as shown in Figure 22.



**Figure 22: Control Unit Installation; Figure 1 (Top Left), Figure 2 (Top Right), Figure 3( Bottom Left), ITR (Bottom Right)**

Note: ITR installation hardware shown is of a typical style and may change depending on application. Consult step 7 to determine the appropriate compression sleeve length before installation.

4.3.7 Step 7: Setting Control Rod Gap

When setting control rod gaps and/or the compression sleeve length for anchored systems, the outer nuts are to be positioned to meet maximum extension requirements and the inner nuts or compression sleeve should be positioned or cut to a minimum length that will allow for the maximum compression requirements.

**Equation 2: Compression Sleeve Length for Figure 3**

$$\text{Compression Sleeve Length} = \text{Face-To-Face Dimension of Expansion Joint} + 2 \times \text{Mating Flange Thicknesses} - \text{Total Compression Required}$$



**Equation 3: ITR Compression Sleeve Length**

$$\text{Compression Sleeve Length} = \text{Face-To-Face Dimension of Expansion Joint} - \text{Thickness of Expansion Joint Flanges} - \text{Thickness of ITR Plates} - \text{Total Compression Required}$$

The control rod gaps and/or compression sleeve lengths are to be determined by the project or site engineer. The combined gaps on the control rods are not to exceed the maximum rated movement capabilities of the supplied expansion joint. For unanchored systems there should be no control rod gaps in the control rod hardware, all hardware on the control rods should be snug to the control unit plates/ITR floating flanges as shown in Figure 24.

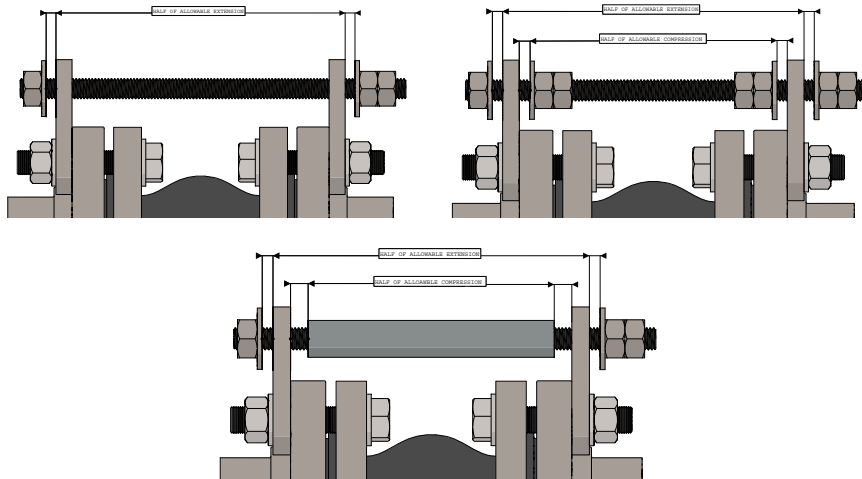

Figure 23: Control Rod Gap, Figure 1 (Top Left), Figure 2 (Top Right), Figure 3 (Bottom)

Note: The ITR designs incorporate the same steps in setting the control rod gaps with the exception that the measurements are taken from the ITR designed floating flanges and not the control unit plates as depicted in Figure 23.

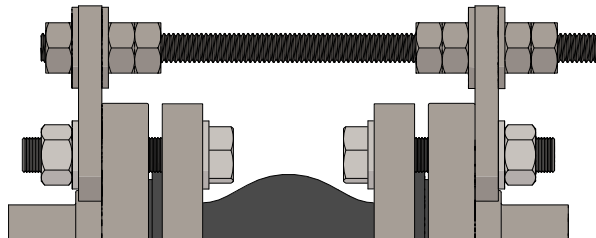

Figure 24: Control Unit Hardware Locked Down

Note: Lock down all available hardware per type of configuration installed, image depicted is of a typical lock down configuration for an unanchored system.



## 5.0 System Testing

### 5.1 System Pressure Test:

Follow pressure test instructions set by site engineer. Lock down all control unit hardware before beginning any pressure testing of the rubber expansion joints as shown in Figure 24. Pressure test should not exceed 1.5 times the operating pressure for 10 minutes. Refer to part specific drawing for pressure rating and details.

### 5.2 After Pressure Test:

After conducting the pressure test, de-pressurize the system and check the flange bolting. Tighten as necessary as bolts may loosen as rubber sealing bead takes a set. Follow proper torquing instructions as stated in Section 4 Step 5 of the installation procedures.

## 6.0 Operation and Maintenance Procedures:

### 6.1 Inspection of Rubber Expansion Joint at Shut-Down:

#### 6.1.1 Cover Inspection:

Rubber expansion joints should be visually inspected at shutdowns. Look for any signs of cracks in the outer cover that shows exposed fabric reinforcement. If fabric reinforcement is exposed, the expansion joint must be replaced.

#### 6.1.2 Tube/Liner Inspection:

If inspection of the internal tube or liner of the expansion joint is possible look for signs of exposed fabric, excessive wear or cracking. If the inner tube or liner shows any of these signs, the expansion joint must be replaced.

### 6.2 Expansion Joint Bolt Check:

Check expansion joint at least one week after start-up to ensure that bolts are tight on expansion joint and the control unit assemblies if applicable. As any rubber-like material takes a "set" after a period of compression, bolts may loosen; thus resulting in a possible broken seal between the expansion joint and the mating flange. Periodically check bolts to ensure bolts are tight and tighten as necessary.

Note: Ensure system is de-pressurized before tightening flange bolting.

### 6.3 Service Conditions:

Make sure the expansion joint operates within the temperature, pressure, vacuum and movement ratings matching the original requirements. Contact Proco's Customer Service Department by phone: 800-344-3246, facsimile: 209-943-2042, or e-mail: sales@procoproducts.com, if the system requirements exceed those specified.

### 6.4 Expansion Joint Removal:

When removing/replacing the expansion joint from the system the removed expansion joint must **not** be reinstalled into the system. This type of expansion joint utilizes a sealing bead for system sealing and is designed for a one time use. A new expansion joint is required to replace the removed expansion joint.



## 6.5 Spares:

A rubber expansion joint spare should be put in stock in the event a mechanical failure occurs. Stock one (1) spare for each size purchased. Although these expansion joints are engineered to give long dependable service, the cost of equipment downtime, in the event of a mechanical failure, can far outweigh the cost of a spare. Spares will be packaged in waterproof crates and prepared for storage.

## 7.0 Trouble Shooting:

### 7.1 Leaking at the Sealing Bead:

Flange bolts may need to be double-checked and retightened to the specified torque settings.

Note: Ensure the system is depressurized before tightening the flange bolting.

### 7.2 Cracking at the Base of Arch or Flange

Make sure the installed face-to-face dimension is correct so that the joint is not over-extended or over-compressed. Check to see if the pipes are properly aligned to ensure that there is no excessive misalignment. Pipes should not be more than 1/8" out of alignment. Check to see if system is properly anchored or if control units are used. External cracking of cover does not mean failure. This is often caused by exposure to strong sunlight in an extended condition. If cracking extends to the fabric reinforcing member, the expansion joint must be replaced.

### 7.3 Excessive Ballooning of Arch:

Ballooning is usually an indication of deterioration of the joint's strengthening members or excessive pressure in the system. Service conditions should be double-checked and a new joint must be installed.



Appendix A: Torque Data Table

**Table 1: Style 240/242 Torque Data**

Nominal Pipe Size		Bolt Torque							
		Step 1		Rest	Step 2		Rest	Step 3	
in.	mm	ft-lbs	N-m	Minutes	ft-lbs	N-m	Minutes	ft-lbs	N-m
1	25	18	25	30	30	40	60	45-60	60-80
1.25	32	18	25	30	30	40	60	45-60	60-80
1.5	40	18	25	30	30	40	60	45-60	60-80
2	50	18	25	30	30	40	60	45-60	60-80
2.5	65	18	25	30	35	50	60	50-60	70-80
3	80	25	35	30	45	60	60	60-75	80-100
3.5	90	25	35	30	45	60	60	60-75	80-100
4	100	25	35	30	45	60	60	60-75	80-100
5	125	25	35	30	45	60	60	60-75	80-100
6	150	30	40	30	50	70	60	60-75	80-100
8	200	30	40	30	50	70	60	60-75	80-100
10	250	30	40	30	50	70	60	75-85	100-115
12	300	30	40	30	50	70	60	75-85	100-115
14	350	30	40	30	60	80	60	75-95	100-130
16	400	30	40	30	60	80	60	75-95	100-130
18	450	30	40	30	60	80	60	90-95	120-130
20	500	30	40	30	65	90	60	95-185	130-250
24	600	30	40	30	65	90	60	95-185	130-250
30	750	30	40	30	65	90	60	95-220	130-300

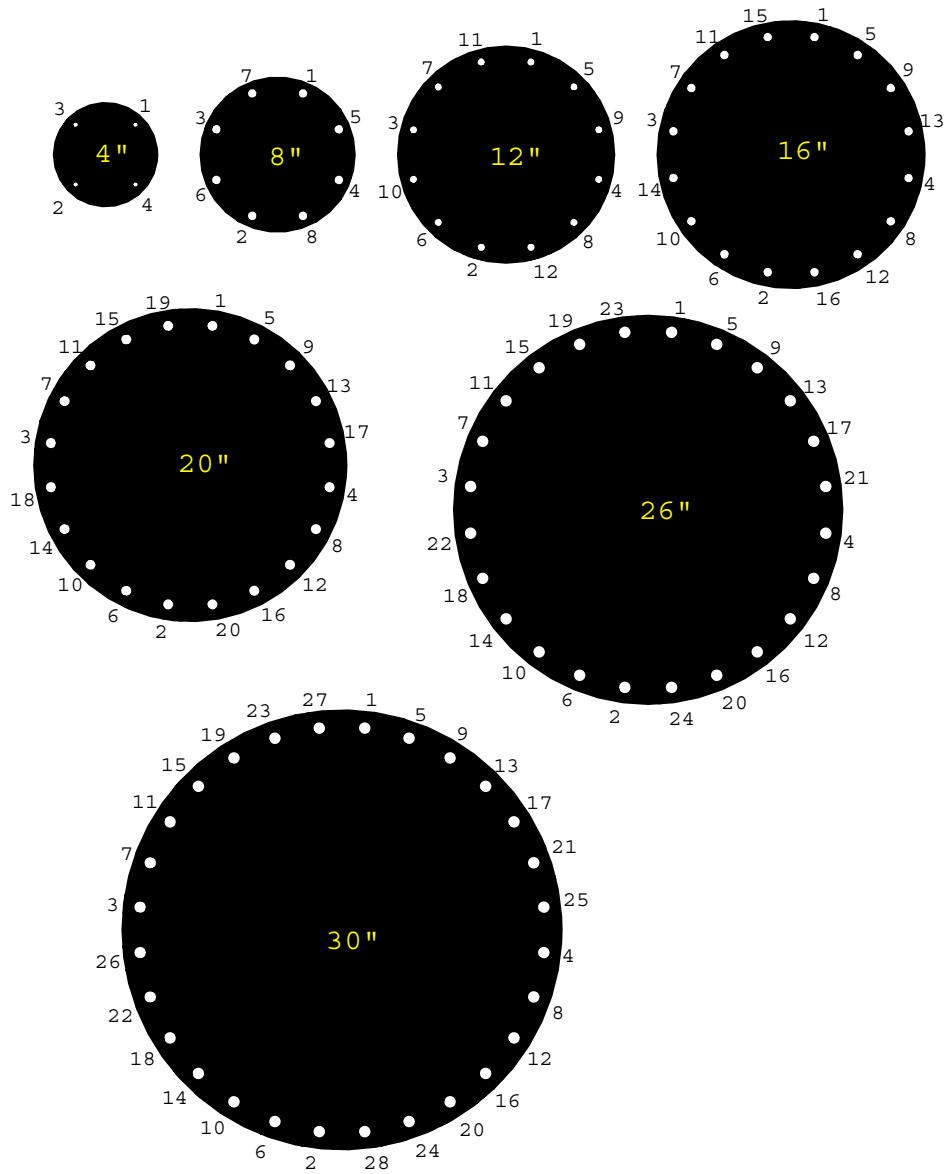

Figure 25: Sample Torque Patterns

**APPENDIX B: Installation Record Sheet**

Attached are the Installation record sheets, below is an overview of the details of the attached installation record sheets.

**Expansion Joint Information:**

Proco Style:	<i>Proco Style of Expansion Joint Supplied</i>
Size (Nom. I.D. x F/F Length):	<i>Nominal I.D. x Face-To-Face Length</i>
Purchase Order No.:	
Date of Order/Shipment:	
Drawing Number:	
Tag No.:	

**System Installation Information**

Installation Date: *Date of Installation*

- 1. Medium Gas/Liquid/Steam: *Type of Fluid and the State of the Fluid in the System*
- 2. Operating Pressure: *Operating Pressure of the System*
- 3. Surge Pressure/Duration: *Surge Pressure Experienced in the System and Duration*
- 4. Operating Temperature: *Operating Temperature of the System*
- 5. Surge Temperature/Duration: *Temperature at Surge Pressure and Duration*
- 6. Confirm Expected Movements in the System:
  - a. Axial Compression: *Expected Axial Compression for Expansion Joint to Compensate*
  - b. Axial Extension: *Expected Axial Extension for Expansion Joint to Compensate*
  - c. Lateral Deflection: *Expected Lateral Deflection for Expansion Joint to Compensate*
  - d. Angular Deflection: *Expected Angular Deflection for Expansion Joint to Compensate*
  - e. Torsional Rotation: *Expected Torsional Rotation for Expansion Joint to Compensate*
- 7. Verify System is Properly Anchored/Guided: *Verify Anchors and Guides in the System*

Notes: \_\_\_\_\_  
 \_\_\_\_\_

- 8. Distance to Nearest Anchor Point (each end): *Measure the Distance to the Nearest Anchor Points*
- 9. Mating Flange Rating/Type (RF/FF): *Rating and Type of Mating Flanges*
- 10. Verify Mating Flanges are Parallel: *Verify that the Mating Flanges are Parallel to each other*
- 11. Verify Centerline Alignment: *Verify that the Point of Installation is Properly Aligned to the Centerline*
- 12. Verify Axial Alignment: *Verify Axial Alignment for the Point of Installation*
- 13. Verify Lateral Alignment: *Verify Lateral Alignment for the Point of Installation*
- 14. Verify Angular Alignment: *Verify Angular Alignment for the Point of Installation*
- 15. Verify Torsional (Rotational) Alignment: *Verify Torsional Alignment for Point of Installation*
- 16. Installation Orientation (Horiz/Vert): *Record Installation Orientation of Expansion Joint*
- 17. Installed Face-To-Face Length (measured in 4 positions):
  - a. 3 O'clock Flange Position: *Measure Face-To-Face Dimension at Specified Flange Position*
  - b. 6 O'clock Flange Position: *Measure Face-To-Face Dimension at Specified Flange Position*
  - c. 9 O'clock Flange Position: *Measure Face-To-Face Dimension at Specified Flange Position*
  - d. 12 O'clock Flange Position: *Measure Face-To-Face Dimension at Specified Flange Position*
- 18. Average Bolt Torque: *Record Average Bolt Torque to Secure Expansion Joint to Mating Flanges*
- 19. Control Rods:
  - a. Number of Control Rods: *Record Number of Control Rods Used*
  - b. Control Rod Gaps/Compression Sleeve Length: *Record Control Rod Gap/Sleeve Length*

Notes: \_\_\_\_\_  
 \_\_\_\_\_

**DOCUMENT TITLE**



Notes:

# Installation Record Sheet



## Expansion Joint Information:

Proco Style:	
Size (Nom. I.D. x F/F Length):	
Purchase Order No.:	
Date of Order/Shipment:	
Drawing Number:	
Tag No.:	

## System Installation Information

Installation Date: \_\_\_\_\_

1. Medium Gas/Liquid/Steam: \_\_\_\_\_
2. Operating Pressure: \_\_\_\_\_
3. Surge Pressure/Duration: \_\_\_\_\_
4. Operating Temperature: \_\_\_\_\_
5. Surge Temperature/Duration: \_\_\_\_\_
6. Confirm Expected Movements in the System:
  - a. Axial Compression: \_\_\_\_\_
  - b. Axial Extension: \_\_\_\_\_
  - c. Lateral Deflection: \_\_\_\_\_
  - d. Angular Deflection: \_\_\_\_\_
  - e. Torsional Rotation: \_\_\_\_\_

7. Verify System is Properly Anchored/Guided: \_\_\_\_\_

Notes: \_\_\_\_\_

\_\_\_\_\_

\_\_\_\_\_

8. Distance to Nearest Anchor Point (each end): \_\_\_\_\_

9. Mating Flange Rating/Type (RF/FF): \_\_\_\_\_

10. Verify Mating Flanges are Parallel: \_\_\_\_\_

11. Verify Centerline Alignment: \_\_\_\_\_

12. Verify Axial Alignment: \_\_\_\_\_

13. Verify Lateral Alignment: \_\_\_\_\_

14. Verify Angular Alignment: \_\_\_\_\_

15. Verify Torsional (Rotational) Alignment: \_\_\_\_\_

16. Installation Orientation (Horiz/Vert): \_\_\_\_\_

17. Installed Face-To-Face Length (measured in 4 positions):

a. 3 O'clock Flange Position: \_\_\_\_\_

b. 6 O'clock Flange Position: \_\_\_\_\_

c. 9 O'clock Flange Position: \_\_\_\_\_

d. 12 O'clock Flange Position: \_\_\_\_\_

18. Average Bolt Torque: \_\_\_\_\_

19. Control Rods:

Number of Control Rods: \_\_\_\_\_

Control Rod Gaps/Compression Sleeve Length: \_\_\_\_\_

Notes: \_\_\_\_\_

\_\_\_\_\_

\_\_\_\_\_

\_\_\_\_\_

\_\_\_\_\_

\_\_\_\_\_

\_\_\_\_\_

**Proco Products, Inc.**  
2431 North Wigwam Dr.  
Stockton, CA 95205  
Phone: 800-344-3246  
Fax: 209-943-0242